



Specifications 2.1  
Order Form 2.2  
Standard Packages 2.3  
Standard Accessories 2.4  
Door Hardware Locations and Dimensions 2.5  
Frame Detail 2.6  
Frame Header Attachment 2.7  
Standard Fire Frame Profile 2.8  
Door Leaf Detail 2.9  
Additional Standard Opening Sizes 2.10  
Door with Transom 2.11  
Strike Option 2.12  
Standard Subjamb System/L-Clip 2.13  
Door Packaging 2.14  
Fire Door Installation 2.15  
Installation Guide 2.16  
Maintenance Instructions 2.17  
Painting Instructions 2.18  
Warranty 2.19

**ADVANTAGE DOOR**  
**DOMINION BUILDING PRODUCTS**  
**SPECIFICATIONS - PREASSEMBLED DOOR SYSTEM**  
**FIRE RATED**

The DOMINION preassembled walk-door system is designed and produced by Dominion Building Products, Inc., Specifically for pre-engineered metal buildings. The following specified door, frame, subframe and hardware are standard and are completely preassembled at the factory. Dominion reserves the right to change component specifications or substitute components of similar quality without notification to it's customers.

**DOOR SPECIFICATIONS**

Standard doors shall be made of electrogalvanized steel sheets (specify 20 or 18 gauge). All doors to be 1 3/4" thick with a patented two-panel design to insure structural integrity.

Doors will be fabricated rigid, neat in appearance, and free from defects, warpage, and buckle. Exposed welds to be made smooth, flush and invisible. Core is a rigid-cell, foamed-in-place polyurethane with 1.8 lbs/ft density conforming to ASTM D-1622. Insulating core is chemically bonded to all interior surfaces, completely seals unit, and provides total support. Door core has an "R" factor of 14.97.

The lock edge shall be non-beveled with a mechanical interlocking edge seam. An 18 gauge lock ring reinforcement shall be installed in the standard provision for Gov. Series 160/161 cylindrical lock sets, and in accordance with ANSI standard A 115.2.

The hinge edge is non-beveled, non-handed, and reinforced with a 7 gauge hinge reinforcement attached at each hinge location. The doors are prepared for 4 1/2" full-mortise template hinges per ANSI/SDI 100.

All doors shall have 16 gauge flush mounted top and bottom channels to prevent water penetration.

All doors shall be factory prepared with a 5 1/2" x 16" 16 gauge galvanized steel reinforcement for closer installation.

All 20 gauge standard doors for metal walls can be ordered with a textured outside skin or smooth skin.

**FRAME SPECIFICATION**

Standard frames shall be made from electrogalvanized steel sheets of 16 gauge material. Frames shall be double rabbeted. Frame stops shall be a minimum of 5/8". Standard frames shall be 4 3/4" in width with a throat size of 3 3/4".

The hinge jamb shall be reinforced with a 7 gauge plate, and prepared for a full mortise 4 1/2" template hinge. The strike jamb shall be prepared for a 4 7/8" ASA universal strike per ANSI standard A 115.2.

**DOOR/FRAME FINISH**

All doors, frame headers and frame jambs shall be thoroughly cleaned, prime coated and then top coated with a smooth, durable finish capable of passing a 200 hour salt spray test in accordance with ASTM specifications B-117 and a 500 hour humidity test in accordance with ASTM specifications D2247. Weatherometer test results - 1000 hrs. Color selection is white or bronze.

## **SUBFRAMING**

Subframing shall be factory installed to the door jambs and consist of two 16 gauge galvanized steel C-channels to match the specified girt depth.

## **STANDARD HARDWARE AND COMPONENTS**

LOCK SET shall be a commercial Grade II cylindrical lever lock with US26D finish having a 2 3/4" backset. Meets requirements of Federal Specifications FF-H-106H Series 160 and ANSI 4000 Grade II.

HINGES shall be (3) 4 1/2" non-removable pin template hinges with color coded finish. Meets Federal Specifications FF-H-116C and ANSI A156.1.

THRESHOLD shall be saddle type 4 3/4", factory cut, with an aluminum mill finish. Meets ADA requirements.

WEATHER STRIP shall be santoprene bulb style. Factory installed to the jamb and header stops.

SWEEP shall be a bolt on.

JAMB CLIPS shall be of 12 gauge galvanized steel.

FASTENERS shall consist of (4) 1/2" masonry anchor bolts; (25) #10 self-drilling screws; (2) masonry screws; (6) 1/4" bolts and locknuts.

## **PACKAGING**

Preassembled door systems shall be packaged in heavy-duty wooden crates and skidded for forklift handling.

## **CONFORMANCE TO NATIONALLY ACCEPTED SPECIFICATIONS AND STANDARDS**

The DOMINION system, when properly specified, will meet standards that conform to the following specifications:

- \* ANSI A151.1-81/ISDSI-105-Test procedure and acceptance criteria for physical endurance. The materials provided in the door unit shall pass a minimum of 1,000,000 cycles, level A without failure.
- \* ANSI A151.1-81-Test procedure for twist and torque resulting in maximum deflection at 300# = .800" max. Permanent set = .029".
- \* ANSI/ISDSI-101-Air infiltration performance standard for insulated steel door systems. Test method ASTM E283-73. Resulting air infiltration not exceeding .20 cubic feet per minute per foot crack space.
- \* ANSI/ISDSI-103-Minimum acoustic performance standard for insulated steel door systems. Test method ASTM E90-61T. Resulting STC rating of 26.
- \* ANSI/ISDSI 107-Thermal performance of insulated steel door systems. Test method ASTM C-236. Maximum thermal transmittance of .25 BTU/Hr. Polyurethane units to carry a minimum of 14.5 R rating.



# Dominion Preassembled FIRE Doors

## Price List

Aug 1999

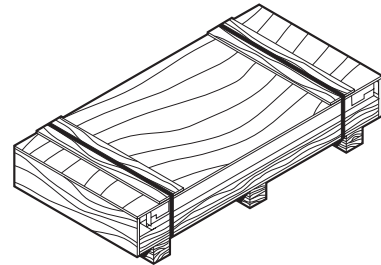
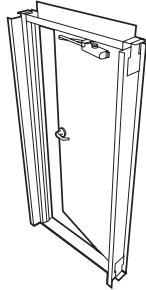

SIZE	COLOR	LIST PRICE	WEIGHT
<b>3070</b>	<b>WHITE BROWN</b>		<b>300 LBS</b> including skidding
<p>3070 FIRE Walk doors are completely preassembled including subframe; 18 gauge galvanized insulated door; 4 3/4" 16 gauge galvanized frame; grade II entry lock; 4 1/2" x 4 1/2" BB NRP hinges; aluminum threshold, Santoprene weatherseal, three fingered concealed sweep. Door and frame have a baked on primer finish, White or Bronze. Doors and frames feature a registered 1 1/2 hour fire label from UL (Underwriters Laboratories). The builder is responsible to ensure the Dominion door meets all applicable codes. Doors are packaged in heavy duty wood crating.</p>			
<b>4070</b>	<b>WHITE BROWN</b>		<b>350 LBS</b> including skidding
<p>4070 FIRE Walk doors are completely preassembled including subframe; 18 gauge galvanized insulated door; 4 3/4" 16 gauge galvanized frame; grade II entry lock; 4 1/2" x 4 1/2" BB NRP hinges; aluminum threshold, Santoprene weatherseal, three fingered concealed sweep. Door and frame have a baked on primer finish, White or Bronze. Doors and frames feature a registered 1 1/2 hour fire label from UL (Underwriters Laboratories). The builder is responsible to ensure the Dominion door meets all applicable codes. Doors are packaged in heavy duty wood crating.</p>			
<b>6070</b>	<b>WHITE BROWN</b>		<b>460 LBS</b> including skidding
<p>6070 Walk doors are completely preassembled including subframe; 18 gauge galvanized insulated door; 4 3/4" 16 gauge galvanized frame; grade II entry lock (active leaf); 4 1/2" x 4 1/2" BB NRP hinges; aluminum threshold, Santoprene weatherseal, three fingered concealed sweep. 6070 doors come standard with astragal and surface bolts on inactive door leaf. Door and frame have a baked on primer finish, White or Bronze. Doors and frames feature a registered 1 1/2 hour fire label from UL (Underwriters Laboratories). The builder is responsible to ensure the Dominion door meets all applicable codes. Doors are packaged in heavy duty wood crating.</p>			

# Dominion Preassembled FIRE Doors

## Accessory Price List Feb '99

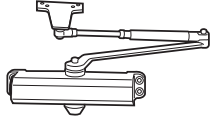

**Standard Closer**  
Grade 3 closer with backcheck and dual closing adjustment.  
**Add:**

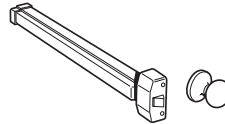

**Panic Device w/Knob**  
Type I, Grade 1 rim type panic device. US26D finish with exterior Key-In-Knob function.  
**Add:**

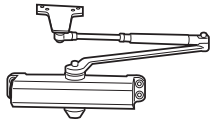

**Heavy Duty Closer**  
Grade 1 heavy duty closer with backcheck and dual closing adjustment.  
**Add:**

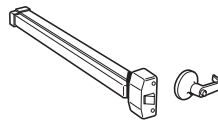

**Panic Device w/Lever**  
Type I, Grade 1 rim type panic device. US26D finish with exterior Key-In-Knob function.  
**Add:**

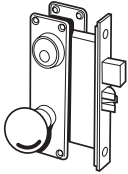

**Mortise Lock w/Knob**  
Heavy duty mortise lock. Grade 1. Intended for heavy use in commercial bldgs where security and durability are required.  
**Add:**

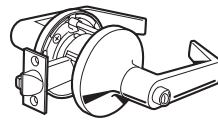

**Lever Lock**  
For handicap accessibility. Heavy duty, Grade 1 for high frequency usage.  
**Add:**

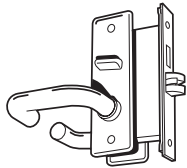

**Mortise Lock w/Lever**  
Heavy duty mortise lock. Grade 1. Intended for heavy use in commercial bldgs where security and durability are required.  
**Add:**

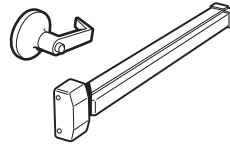

**Mortise Panic**  
Heavy duty Grade 1 panic. Intended for use in commercial bldgs where security and durability are required. Lever.  
**Add:**

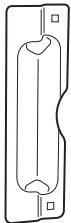

**Latchguard**  
Highly recommended for added security at minimal expense. Satin Chrome finish.  
**Add:**

### 5 basic requirements for Fire Rated Opening:

1. Labeled Fire Door Frame
2. Labeled Fire Door
3. Approved Closer
4. Approved Latching Device
5. Steel Bearing Type Hinges

For more information, refer to the SDI "Basic Fire Door Requirements" tech data manual.

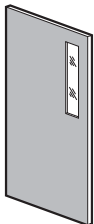

<b>Narrow Lite</b>	<b>4 x 24</b>
Wire	



<b>Vision Lite</b>	<b>10 x 10</b>
Wire	



Door Hardware Locations & Dimensions

8-1-99

Standard 3070 Preassembled Walk Door  
Non-Handed Door System

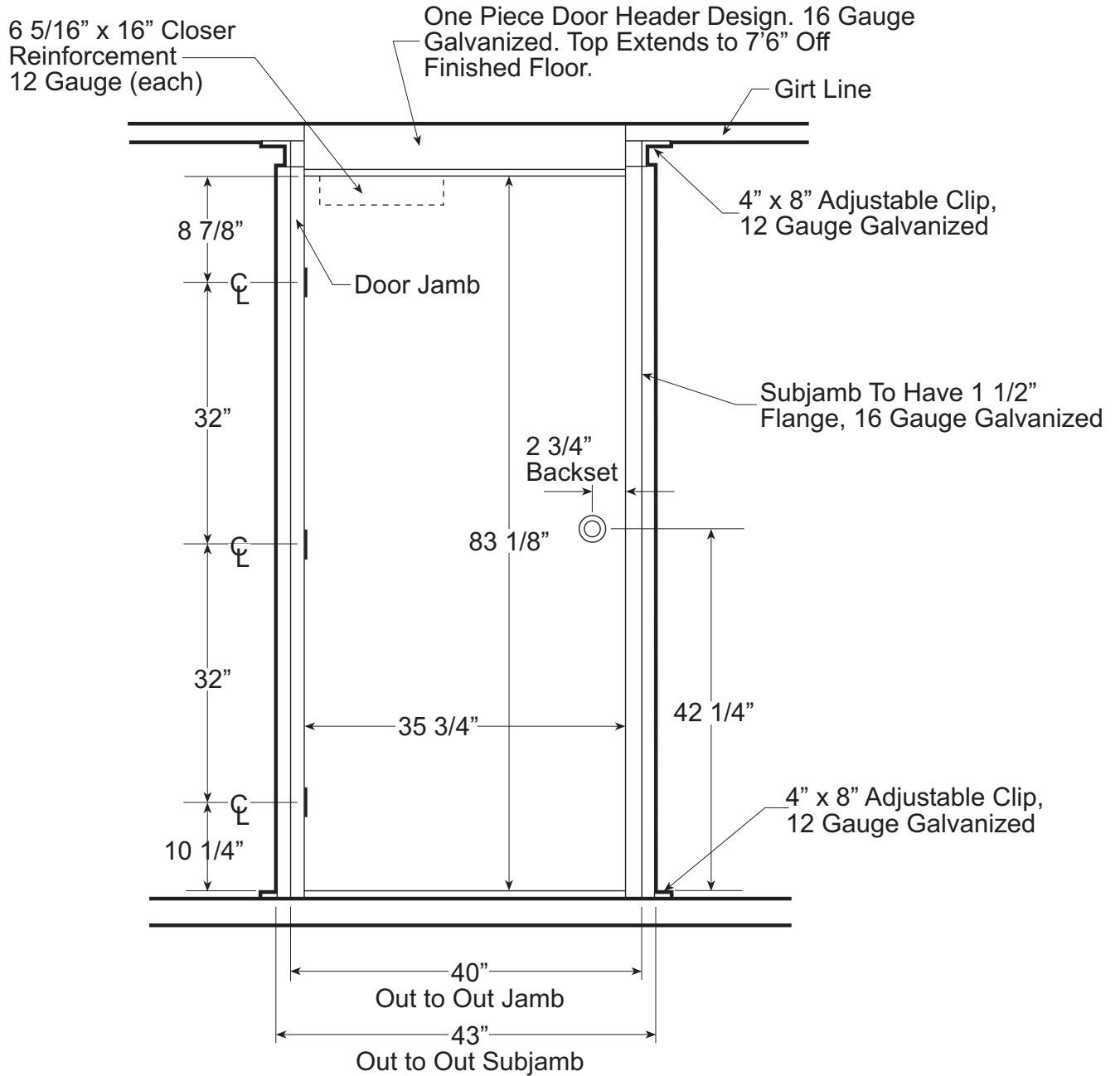



Frame Detail

8-1-99

Standard Fire Frames To Be 16 Gauge Galvanized Steel With Standard White Or Bronze Baked-On Primer Finish. Frames Are Labeled With A 1 1/2 Hour (B) Label From Warnock Hersey.

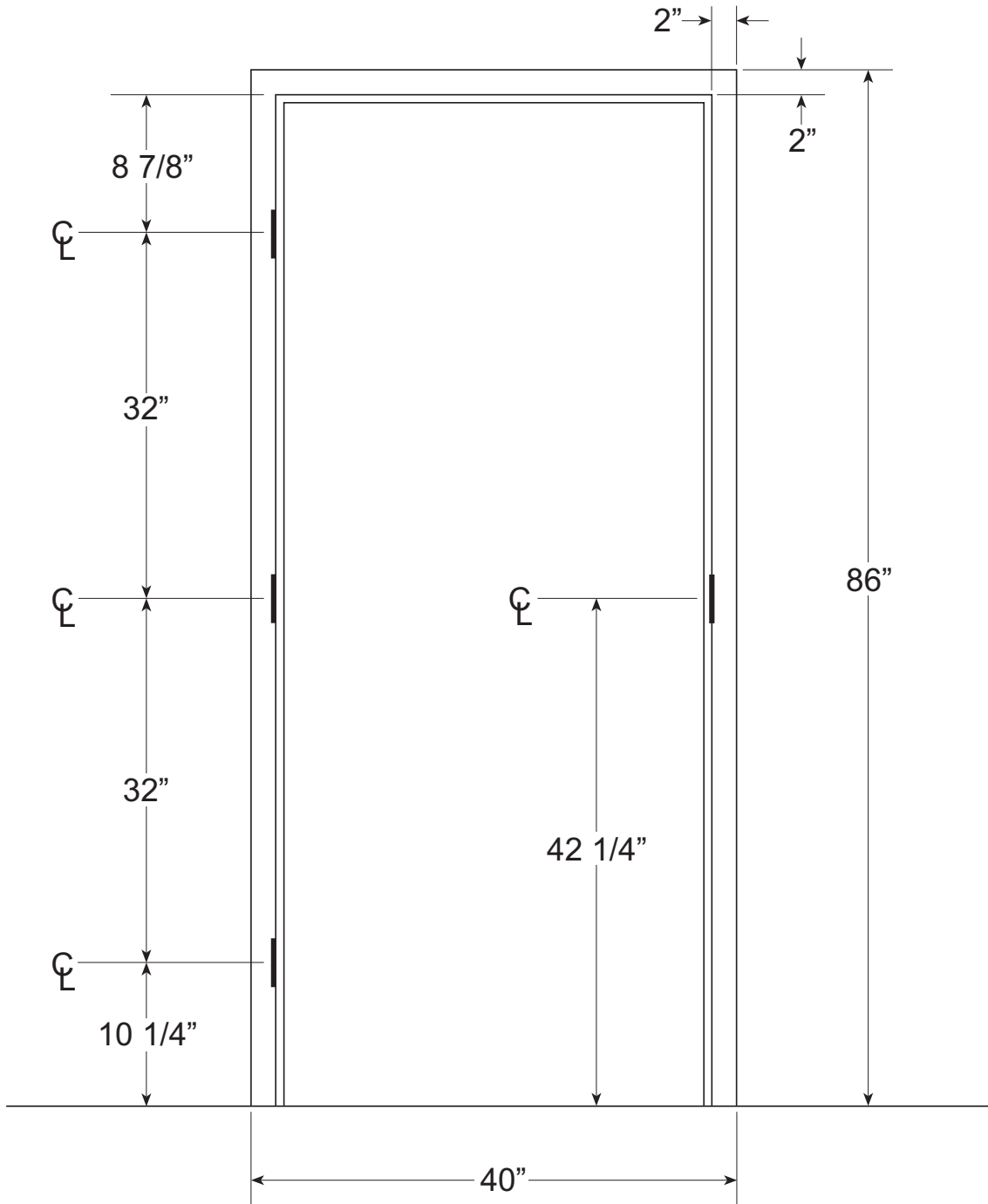



Frame Header Attachment

8-1-99

Frames Are Welded And Are Manufactured Of 16 Gauge Galvanized Steel And Have A Baked-on Primer Finish. Fire Frames Are Labeled With A 1 1/2 Hour (B) Label From Warnock Hersey

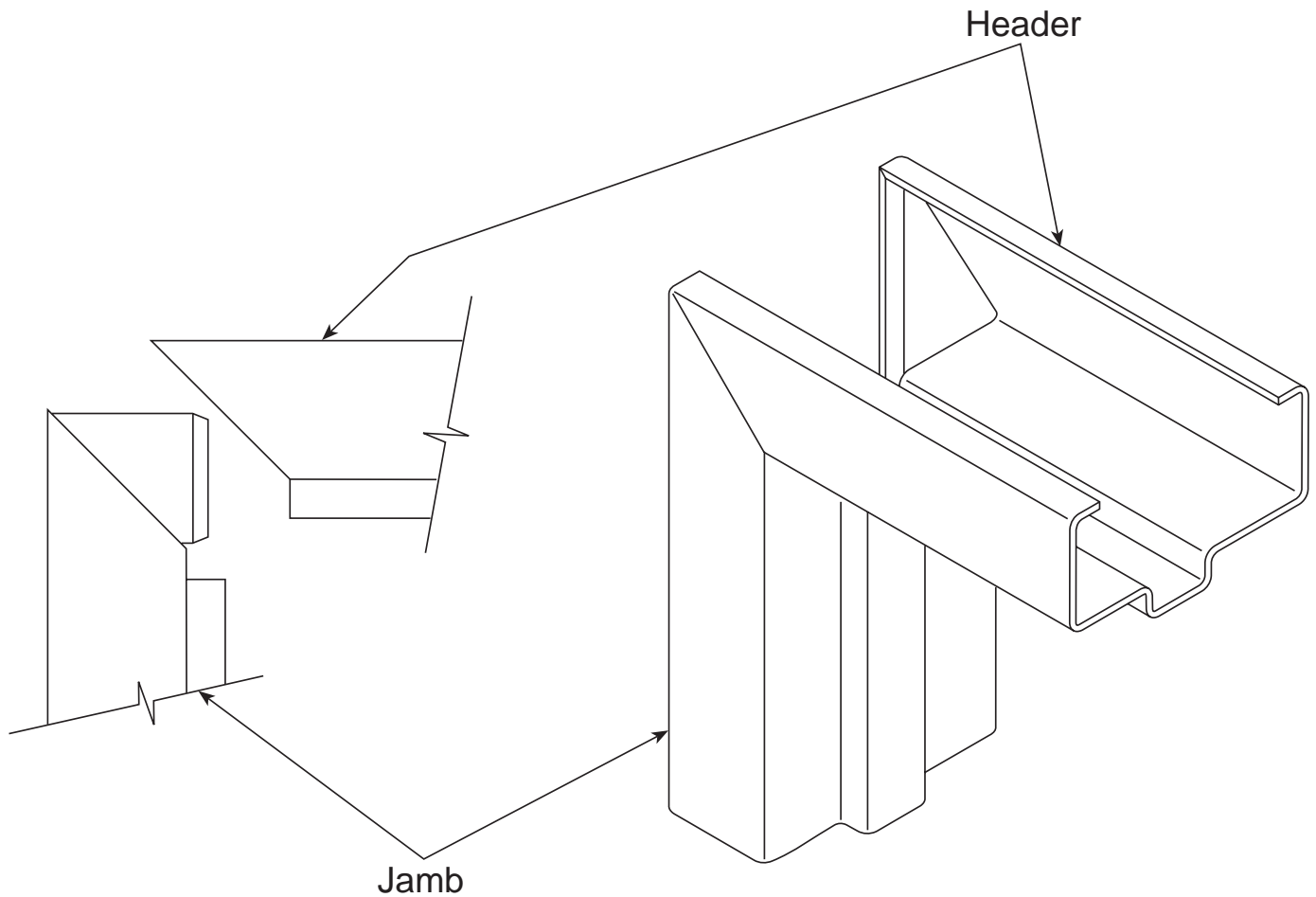



Standard Fire Frame Profile

8-1-99

Standard Frames To Be 16 Gauge Galvanized Steel With Standard White or Bronze Baked-On Primer Finish

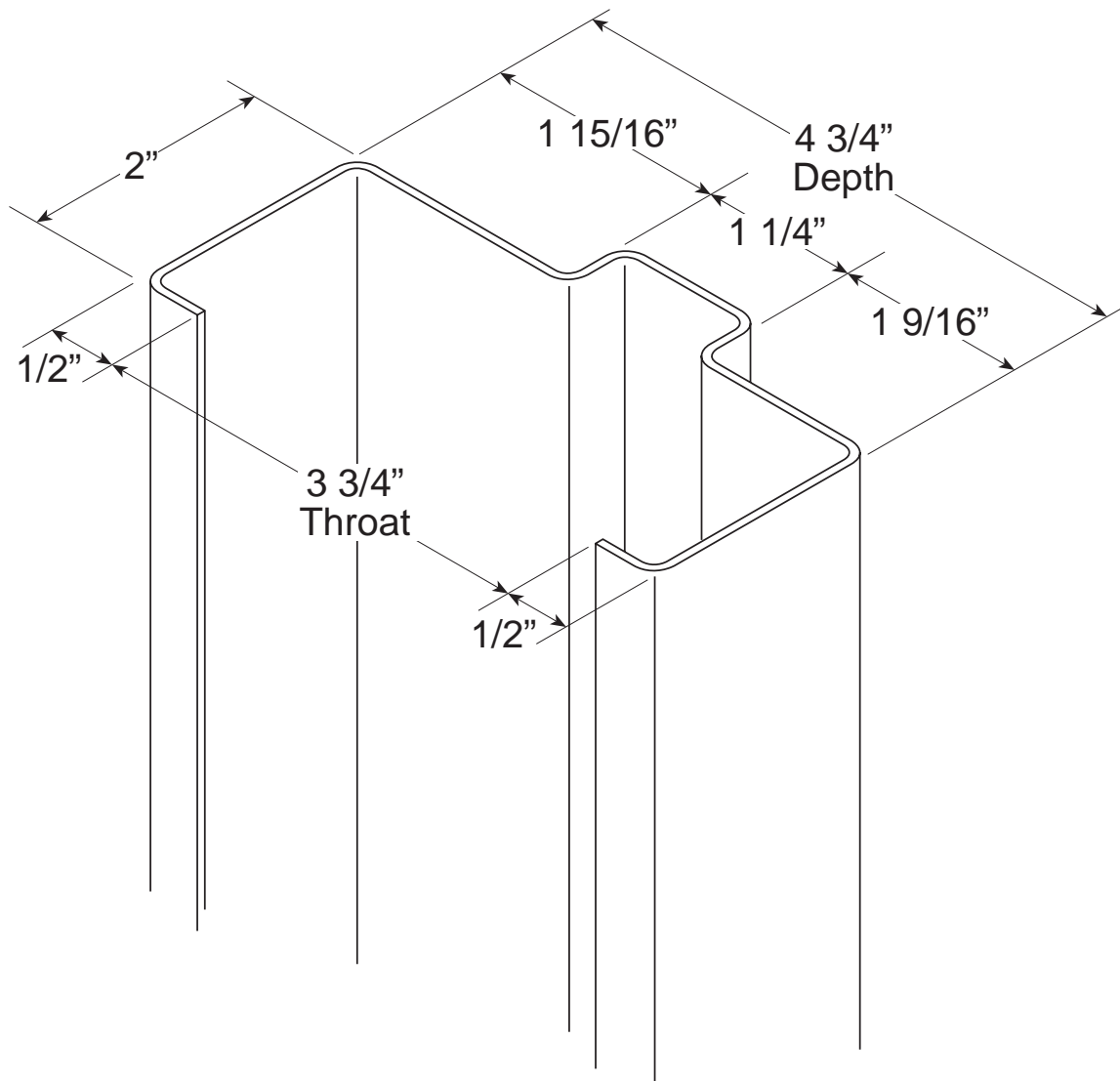

Fire frames include a registered 1 1/2 hour fire label from Warnock Hersey.



Door Leaf Detail

8-1-99

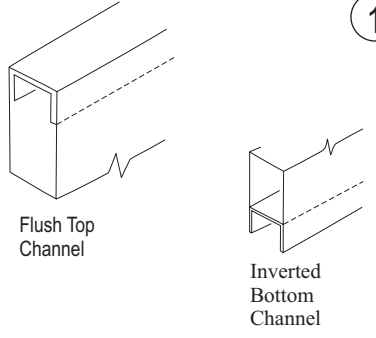
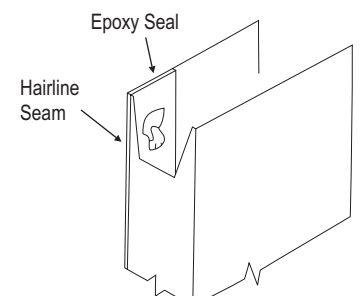
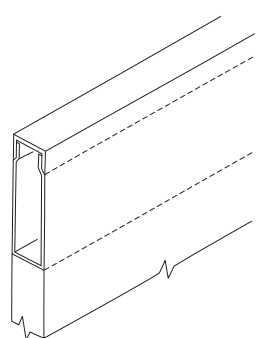
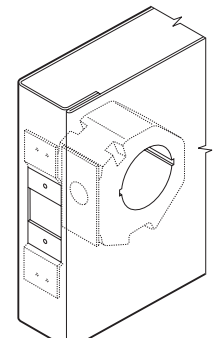
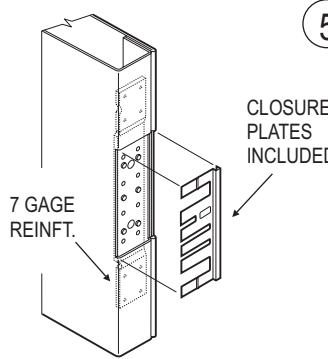
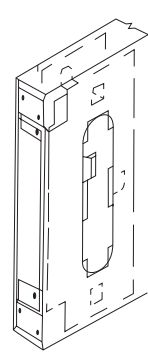
<p><b>16 GAGE STEEL END CHANNELS</b> WELDED TO DOOR</p>  <p>Flush Top Channel</p> <p>Inverted Bottom Channel</p> <p>①</p>	<p><b>VERTICAL EDGES</b></p>  <p>Epoxy Seal</p> <p>Hairline Seam</p> <p>MECHANICALLY INTERLOCKED HEMMED EDGES</p> <p>ALSO AVAILABLE SEAMLESS (WELDED OR BODY FILLER)</p> <p>②</p>
<p><b>CLOSER REINFORCEMENT (OPTIONAL)</b></p>  <p>12 GAGE STEEL CHANNEL 16" LONG</p> <p>③</p>	<p><b>LOCK PREPARATION GOV. 160/161 CYLINDRICAL TYPE</b></p>  <p>(C)</p> <p>(ANSI A115.2) 2-3/4" BACKSET</p> <p>④</p>
<p><b>HINGE PREPARATION</b></p> <p>4-1/2" X .134" HIGH, STANDARD OR HEAVY WT. FULL MORTISE HINGE PREPS</p> <p>ANSI A156.7 TEMPLATE</p> <p>NON-HANDED</p>  <p>7 GAGE REINFT.</p> <p>CLOSURE PLATES INCLUDED</p> <p>⑤</p>	<p><b>LOCK PREPARATION GOV. 86-4 MORTISE TYPE</b></p>  <p>(M) (ANSI a115.1) 2-3/4" BACKSET</p> <p>(B) SIMILAR TO DETAIL LESS FACE CUTOUT</p> <p>(P) SIMILAR TO DETAIL LESS ALL CUTOUT AND REINFORCEMENT</p> <p>⑥</p>

# DOMINION BUILDING PRODUCTS

## 4070 Door System

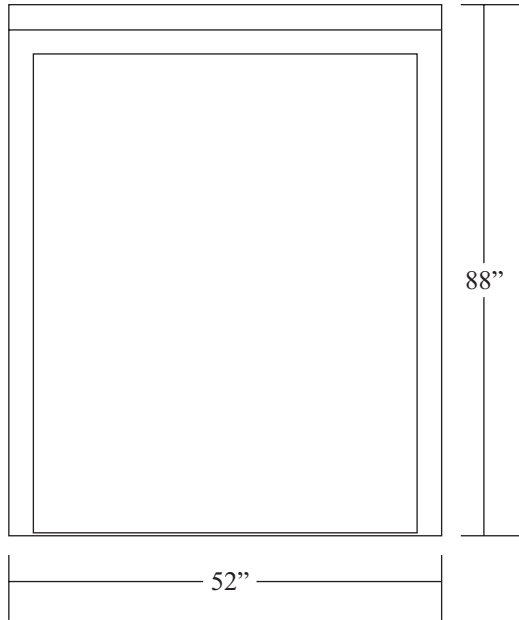

## 6070 Door System

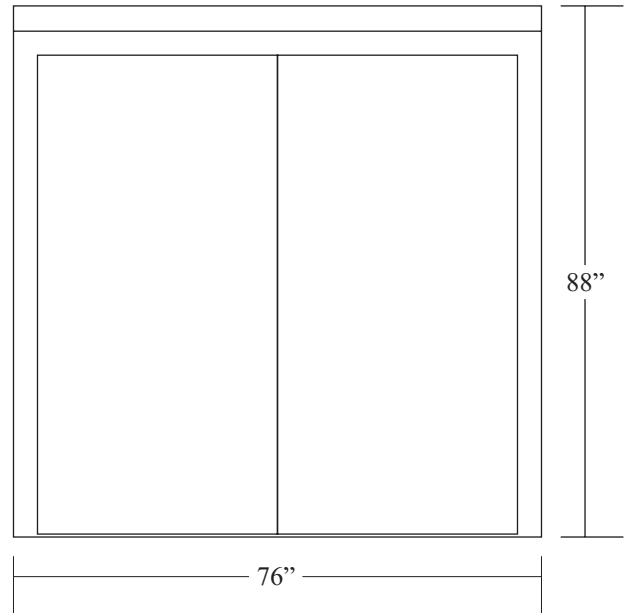

## 8070 Double Door System

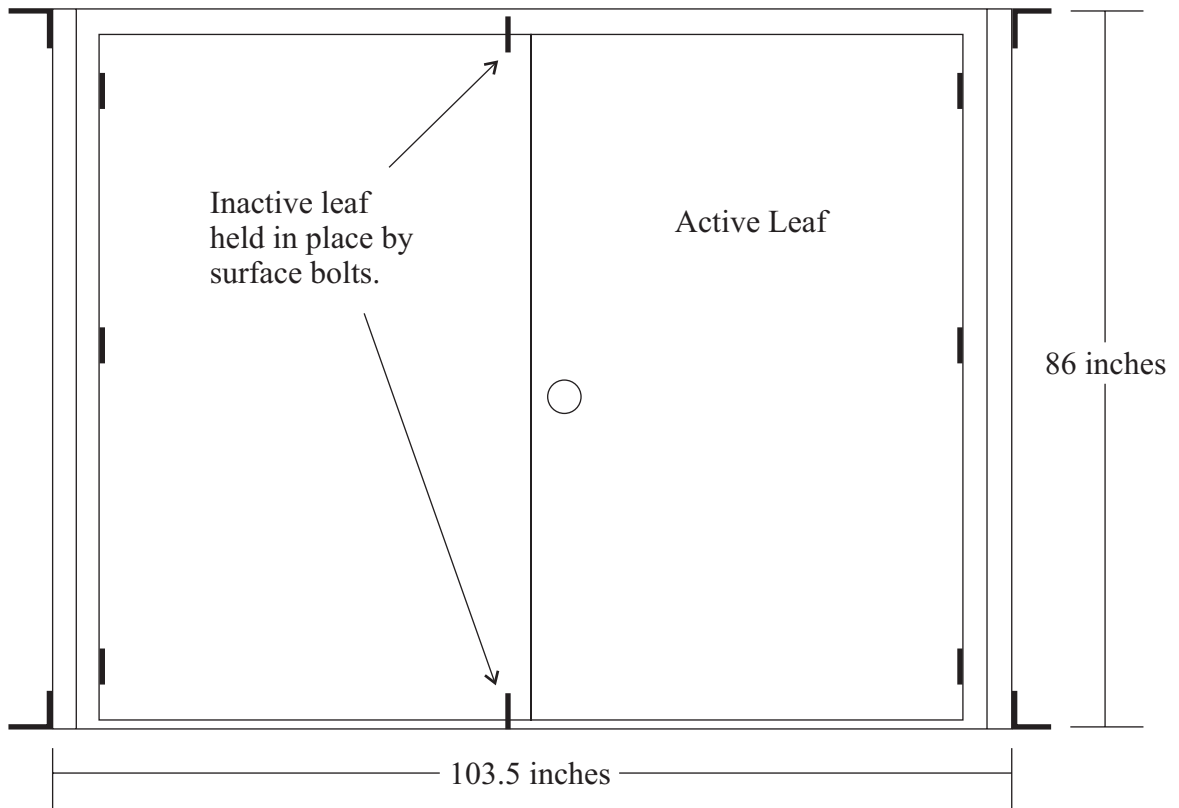

# 6070 Double Door System with Transom

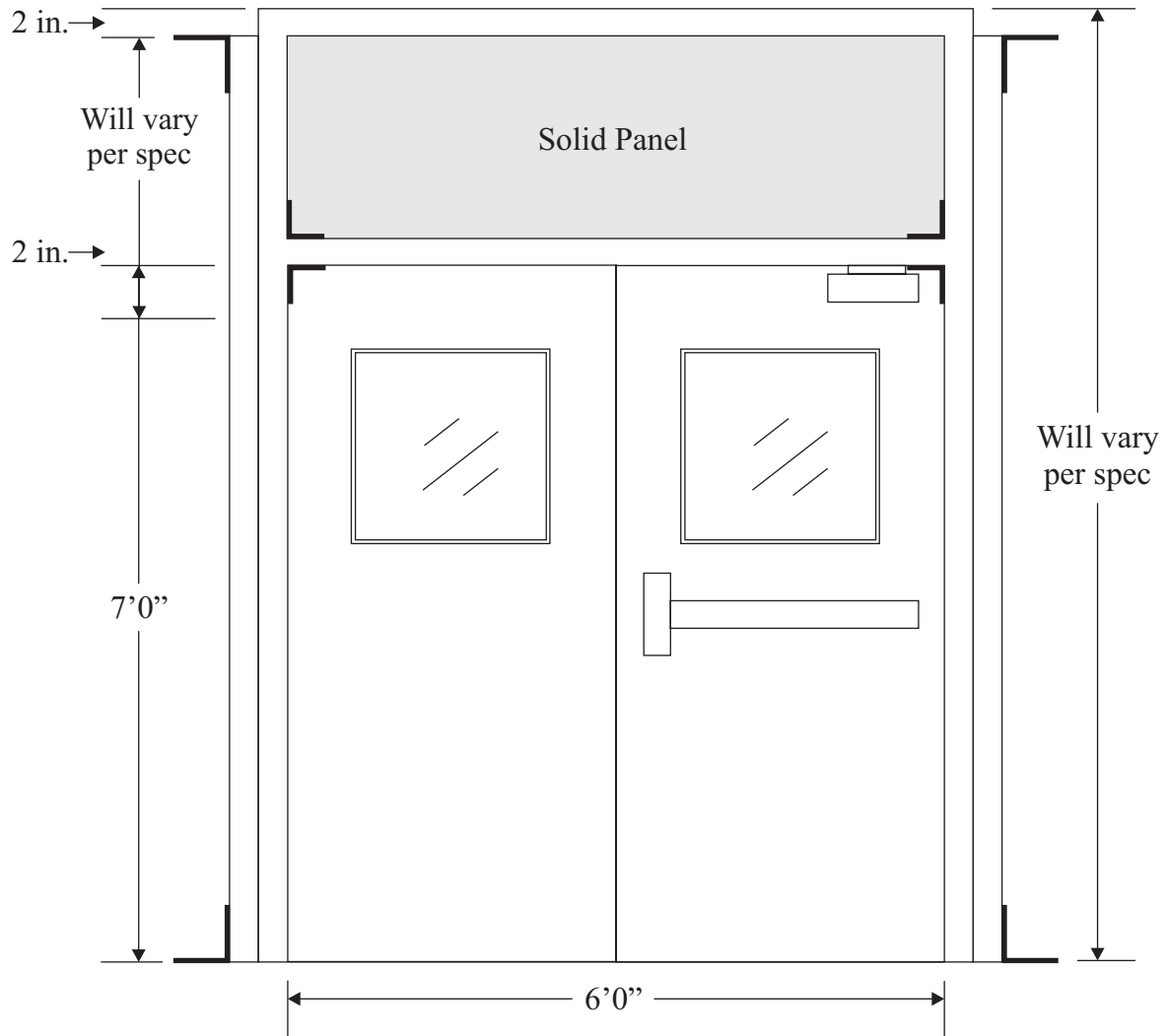

The full opening of the above door is 6 ft. wide and 10 ft. high.  
The subframe system (framed opening) is 10 ft. high and the  
mounting clips will extend to 10 ft.-6 inches.

## Z-Style Astragal for Pairs of Doors

HARDWARE PREPARATIONS	PREFIX
ANSI 4-7/8" Universal Strike	A
ANSI 2-3/4" Cylindrical Strike	C
PLAIN (No Strike Prep)	P
ANSI FLUSH BOLTS (Top & Bottom)	F

HANDED:  
USE LH (L) ASTRAGAL FOR R OR LR ACTIVE OPENING.  
USE RH (R) ASTRAGAL FOR L OR RR ACTIVE OPENING.

Example: AF4471/68R (For RRA)

Finish: PRIME PAINT

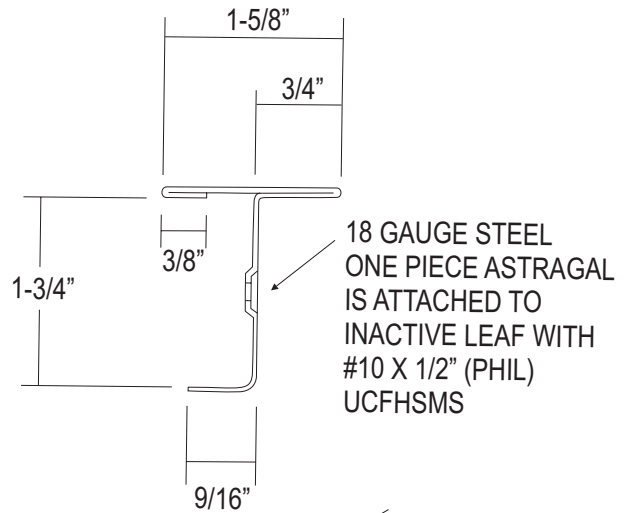

OPTIONAL LANCED FLUSHBOLT PREPARATION SEE 1-415A

LANCED (ANSI) STRIKE MOUNTING PREP SEE 1-415A

41-1/16"

6-8,  
7-0,  
7-2,  
7-10,  
8-0,  
9-0,  
NOMINAL HEIGHTS

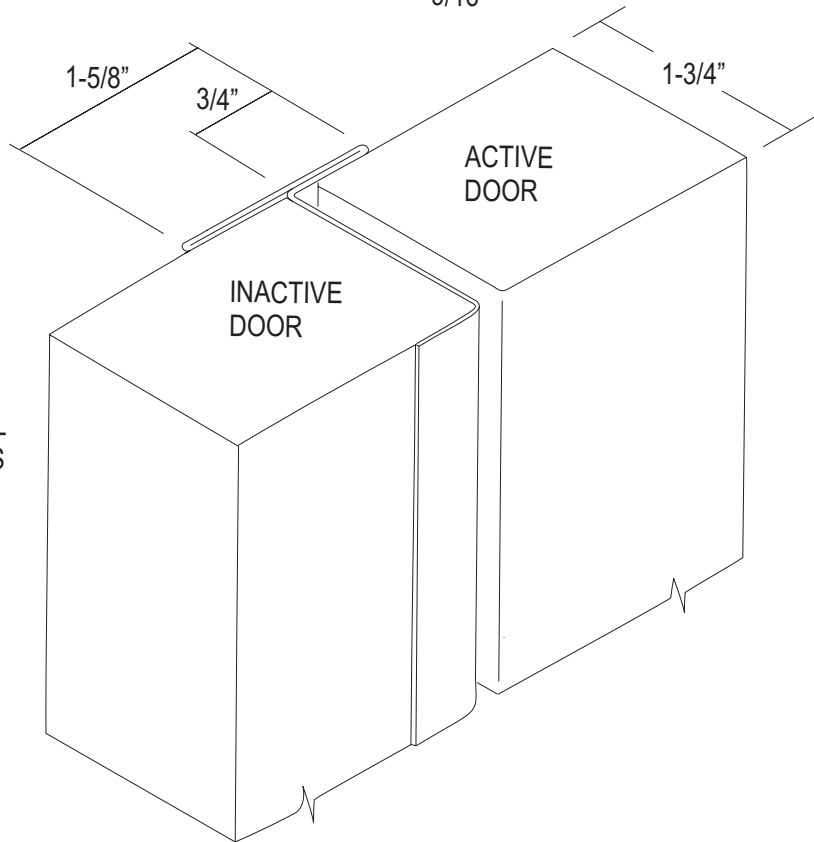

Astragal is shop attached.

Dominion Building Products  
**DOUBLE DOOR SYSTEMS**

**#1 Standard Door Package with One Active Door and One Inactive Door**

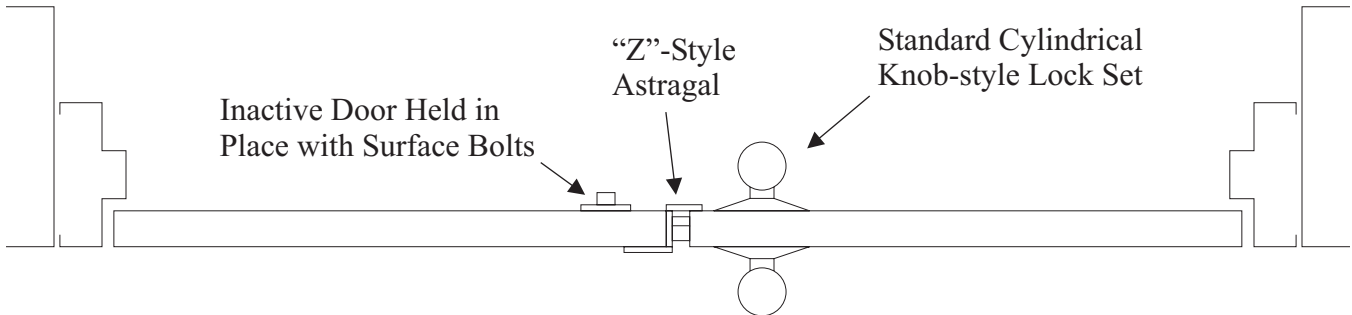

**#2 Both Leafs Active with Removable Center Mullion**

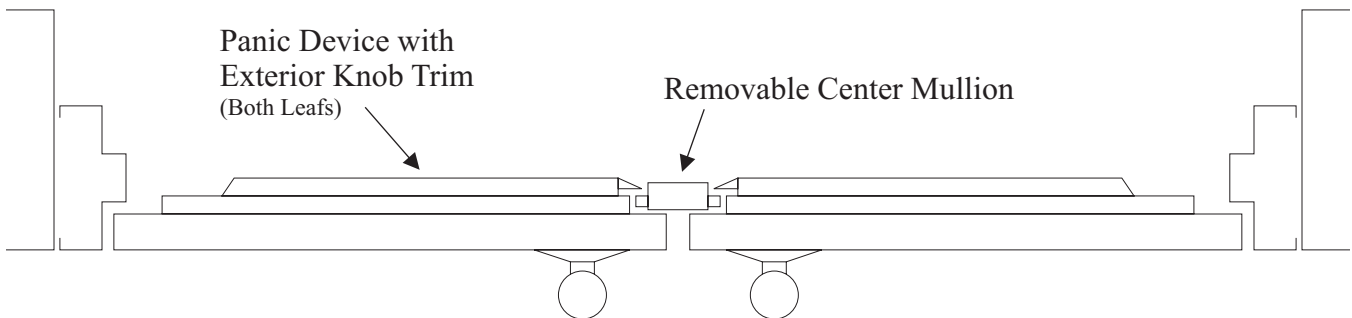

**#3 Both Leafs Active Using Vertical Rod Panic Devices**

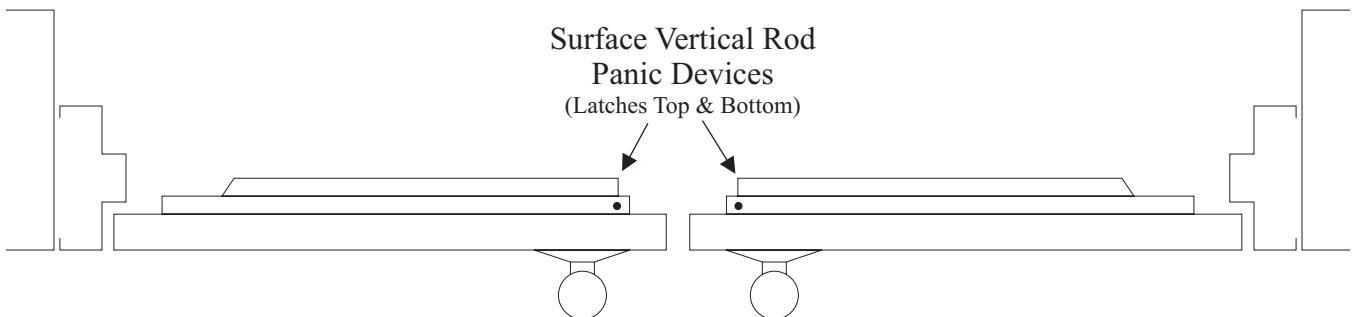

**#4 Both Leafs Active with Push/Pull Hardware**

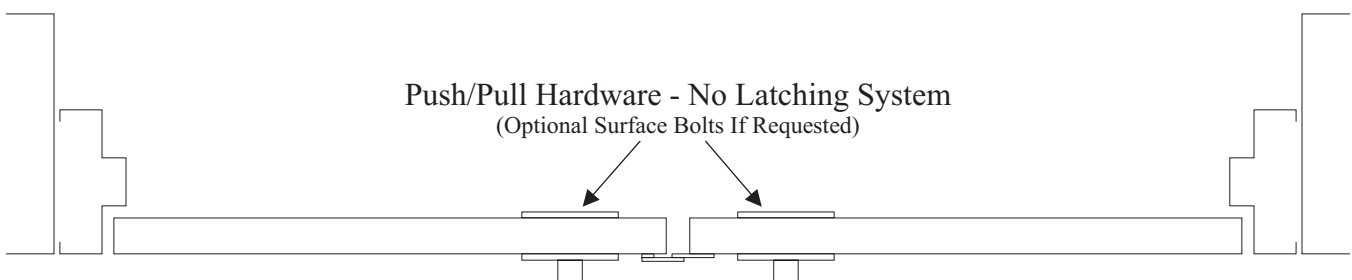

### Both Leafs Active with Removable Center Mullion

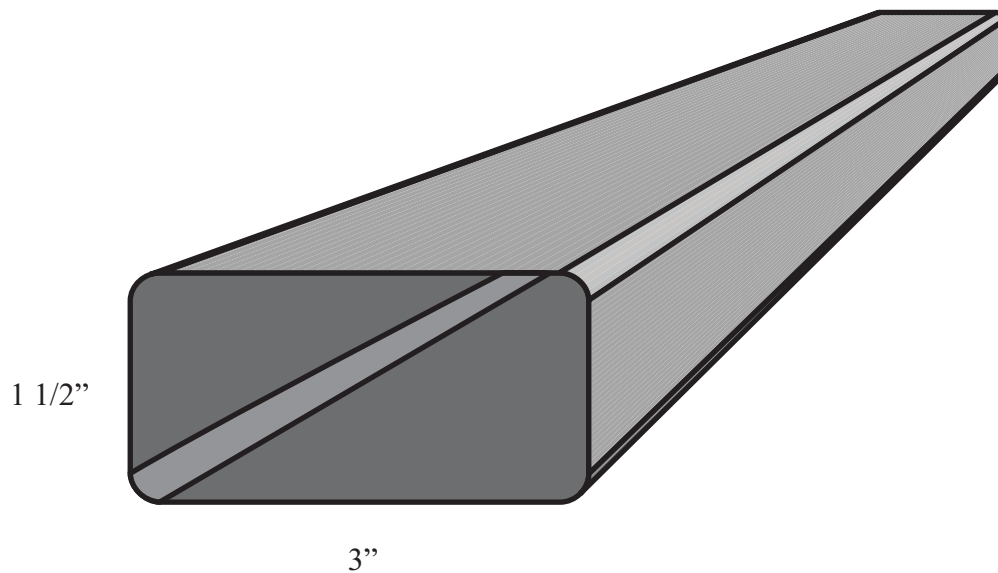
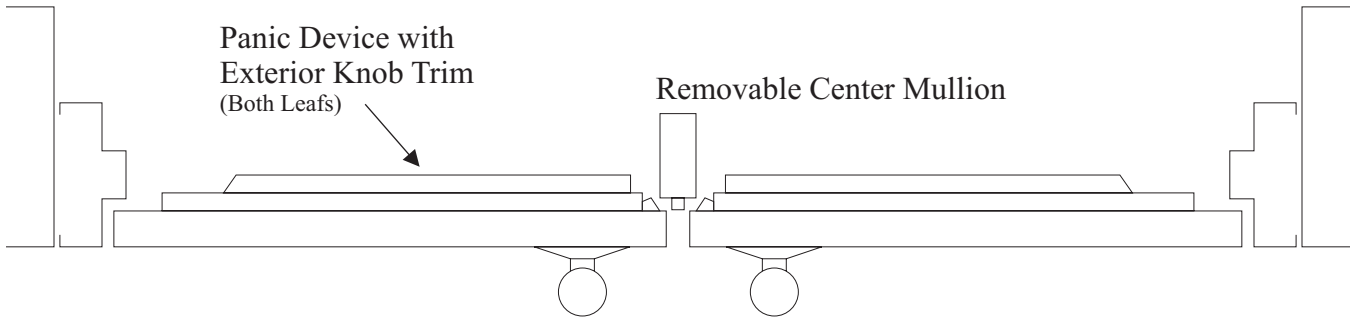



Standard Subjamb System/L-Clip

8-1-99

Subjamb Are Manufactured From 16 Gauge Galvanized Material. The Depths Are Designed to Match Metal Building Manufacturer Girt Depths.

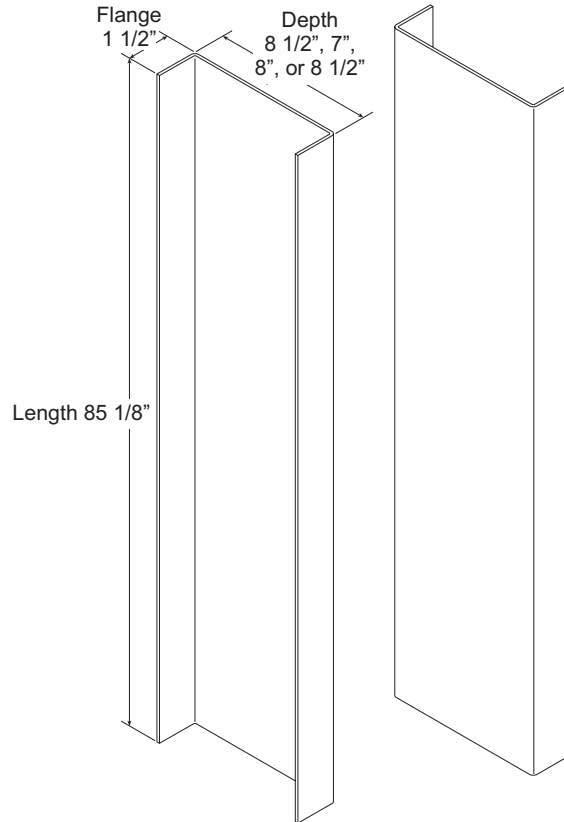

The Adjustable Jamb Mounting Clips Are Constructed From 12 Gauge Galvanized Steel

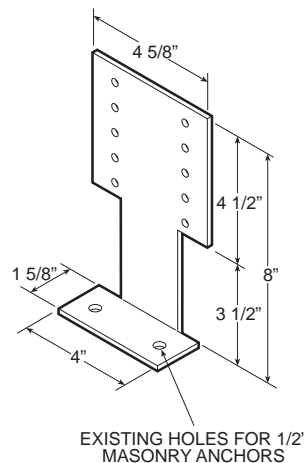



Door Packaging

8-1-99

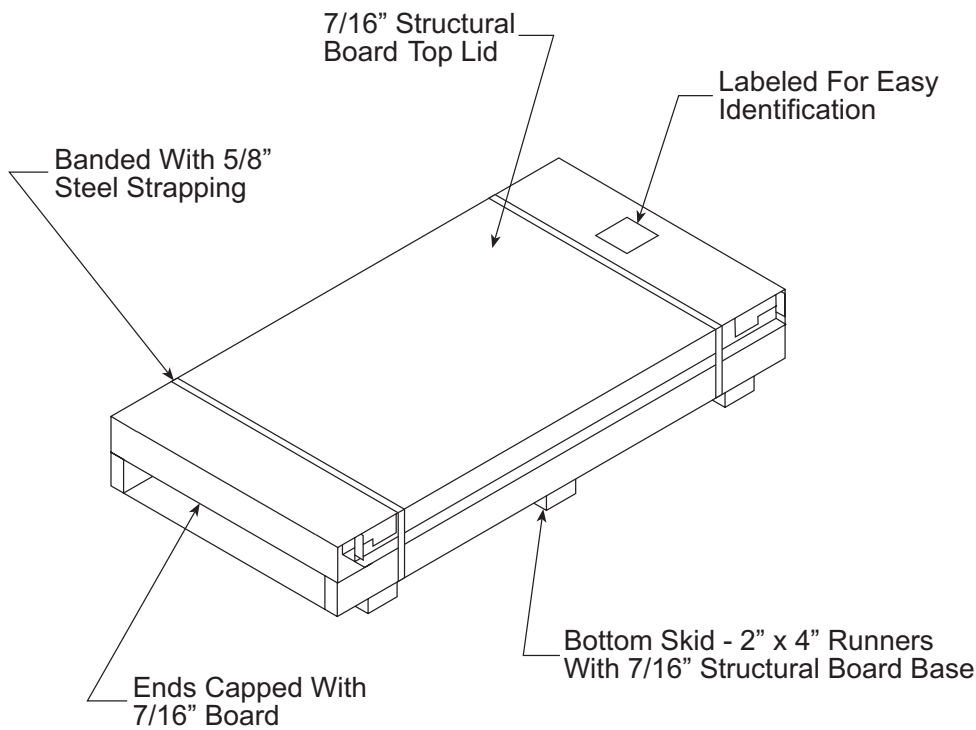

Uncrated Fully Assembled 3070  
Door System Ready For Installation

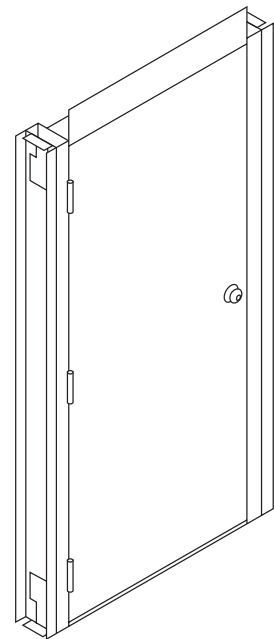

Doors Are Shipped Fully Assembled Including Required Door Hardware, Subjamb,  
And All Hardware Necessary For Installation



Header Girt Attachment

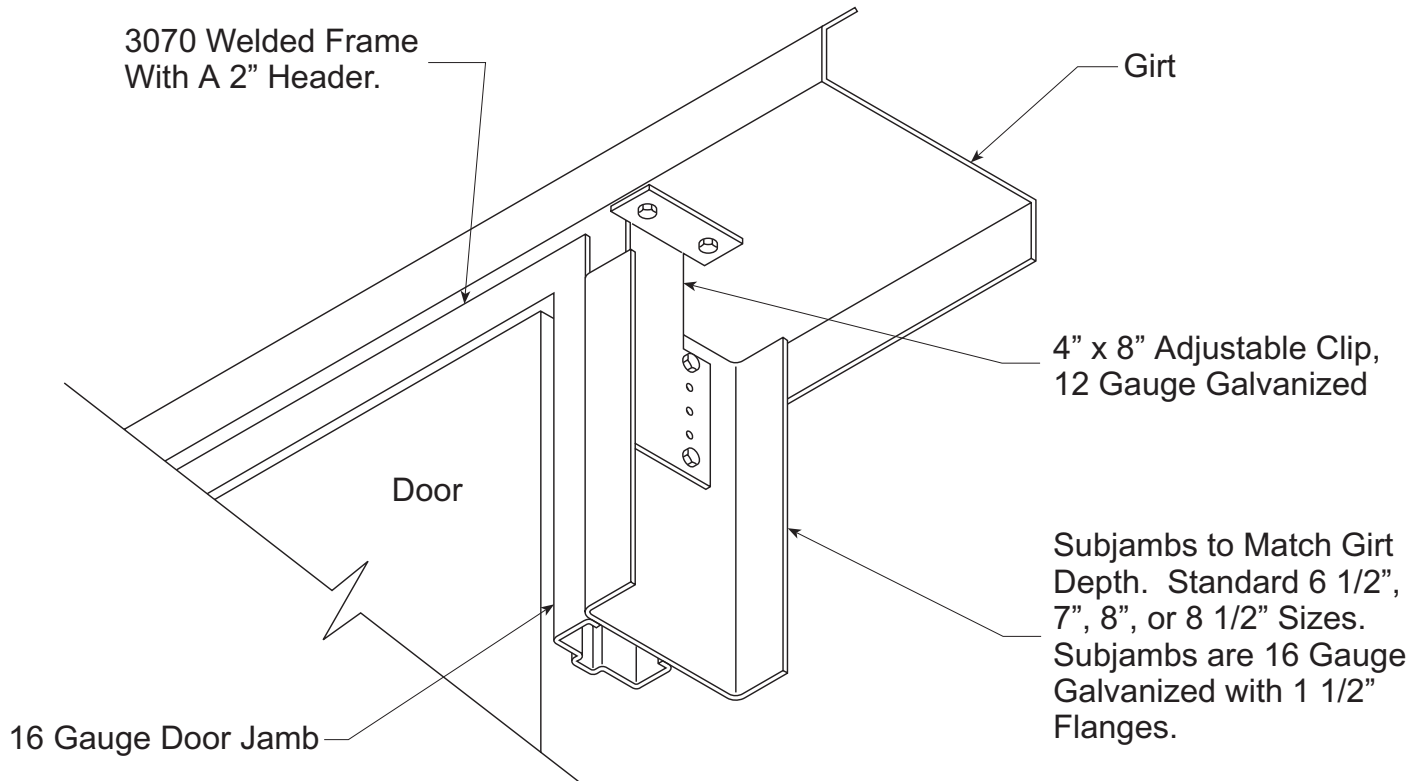



Fire Door Installation - Base Detail

8-1-99

Base Floor Attachment

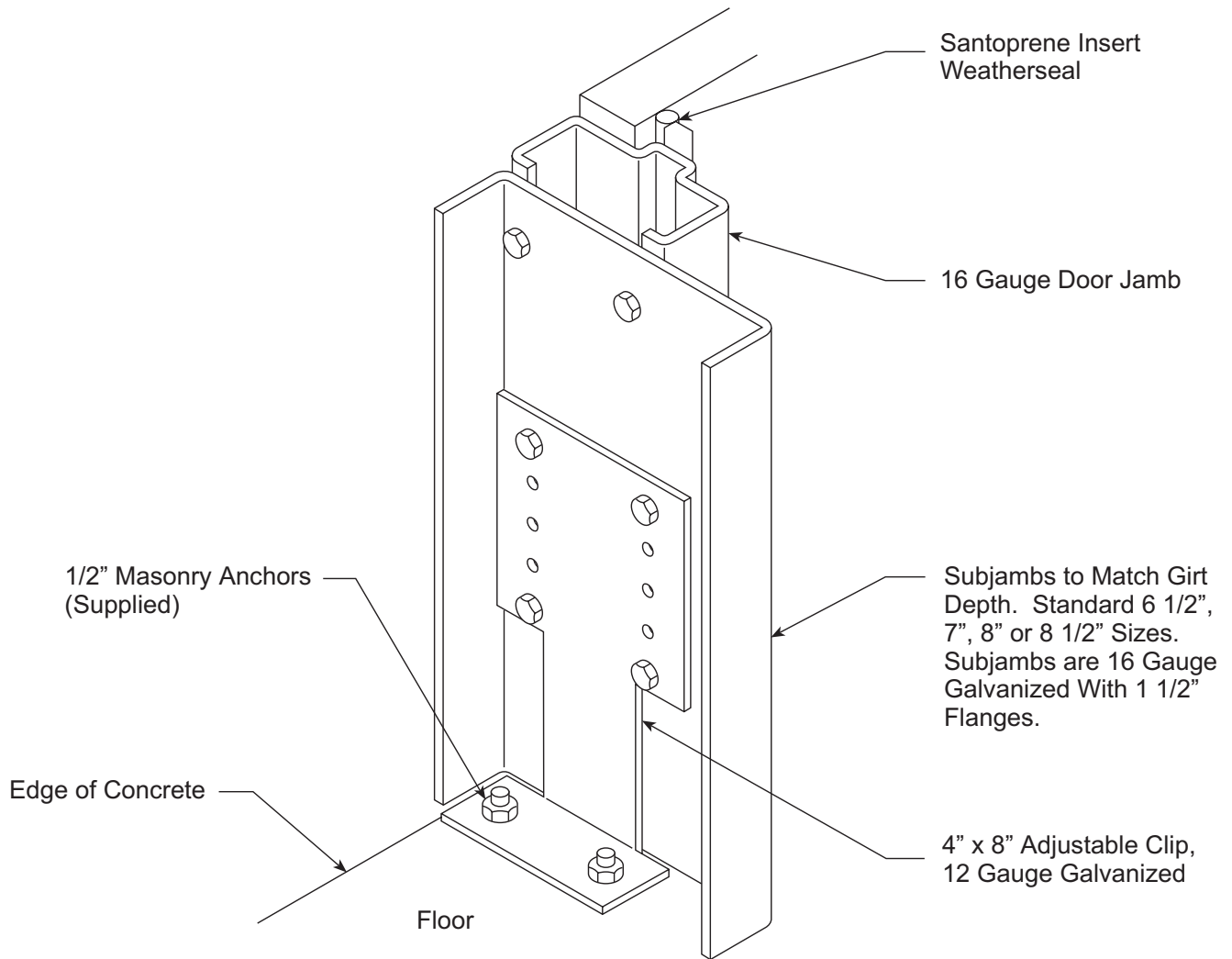



**General Pre-Installation Notes:**

- \* This door is designed to install before the wall panels are put up (although the door can be installed later.)
- \* DO NOT remove the screws holding the door leaf closed until after the door is installed. These screws hold the door/frame square during the installation process.

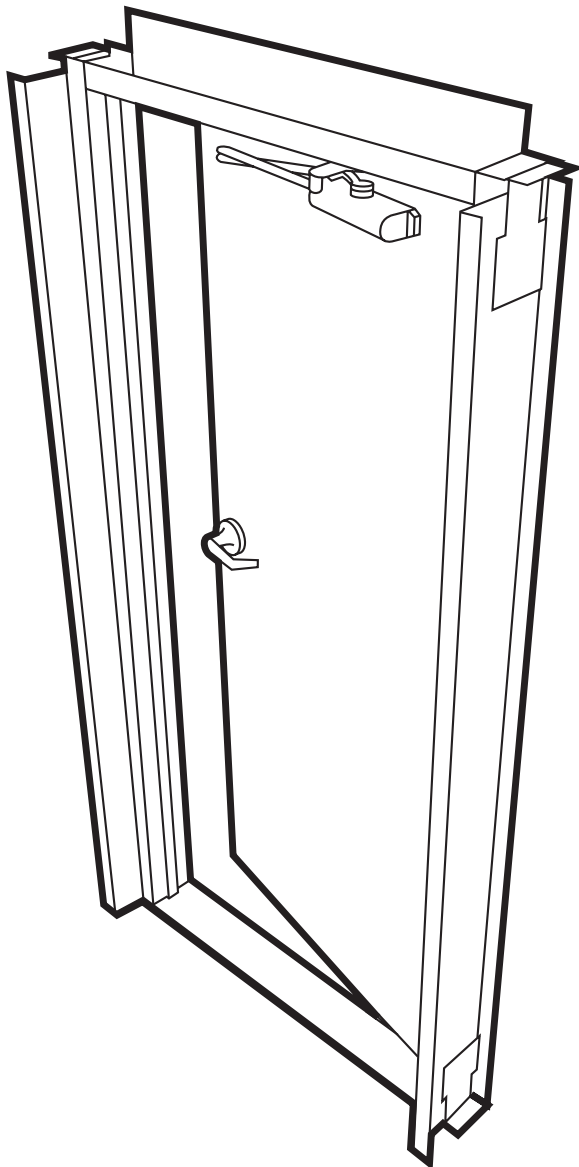

**Installation Steps**

1. After uncrating the door, position under the girt with the outside edge of the threshold flush with the edge of the concrete. The header should be up against the outside face of the girt.
2. Plumb the door unit.
3. When the door is plumb, secure the door header to the face of the girt with 2 self-drilling screws. These screws can be moved later if they interfere with the sheeting or trim.
4. Bolt the door to the floor with the base clips and the (4) anchor bolts provided.
5. Back out the screws holding top jamb clips and slide clips straight up to the girt. Use (6) screws per clip (3 into the subjamb and 3 into the girt.)
6. Remove screws holding door leaf shut.
7. Screw down threshold with the (2) anchors provided. Caulk or grout if needed.
8. Adjust weatherstrip and sweep to eliminate light leaks.

**Adjustments**

If the door does not operate properly:

1. Check frame to ensure plumb and square.
2. Check floor level at each jamb. Shim under side needing adjustment.
3. If gap around door is unequal, shim hinges appropriately.

\*\* For further information, refer to the Steel Door Institute (SDI) Installation and Trouble Shooting Guide. SDI Technical Data Series #122-90.

**TO CHANGE DOOR SWING:** The door swing can be changed in the field on standard 3070 preassembled doors. (Doors with factory installed closer or lights cannot be changed.) Remove jambs from door system; put in new location and reattach the header, threshold, and subjamb. Install door, remove the sweep and reinstall so screws are on the inside of the door.

## 1. Introduction

This document is intended to serve as a general outline of maintenance activities needed for hollow metal doors and frames. However, it should be noted that the door and frame are virtually maintenance free. Maintenance will be, for the most part, associated with accessories and hardware attached to the door and frame.

Maintenance of any product is important and necessary to obtain the maximum benefits of product service and longevity. Hollow metal door and frame assemblies are no exception. In fact, in some cases where the door and frame assembly is used as a "fire rated" fire barrier or a "leakage rated" smoke and draft barrier, proper maintenance is crucial. Basic maintenance to ensure the proper functioning of the assembly is imperative and well worth the effort to provide for life safety.

## 2. Areas to be Inspected

The following items should be periodically checked. The frequency with which these checks are performed must be established at the discretion of the building owner, insurance company and maintenance service. Since doors in different areas of a building access different traffic, the frequency of periodic inspections would occur respectively.

### Hinges

Check all hinges for loose attaching screws, hinge pin wear or other notable defects. Service the hinges or remove defective parts and replace if necessary. The door should always swing freely and smoothly without obstruction from open to latched (when latching device is used) position.

### Locksets, Panic Devices, Fire Exit Hardware

Check all locksets for loose attaching screws, latch wear or other notable defects. Service the lockset or remove defective parts and replace per the manufacturer's recommendation. The door should always latch freely and smoothly without obstruction. Self-latching devices should always function freely and smoothly as the door swings into the closed position. Additional force should not be needed to achieve latching.

### Strike Plate

The strike plate should be firmly attached to the frame or inactive leaf of a pair of doors. Check for loose screw and/or other notable defects. Service or remove and replace strike plate if necessary.

### Closing Devices

Check all closing devices for loose attaching screws, linkage arm and pin wear, fluid leakage or other notable defects. Service the device or remove defective parts and replace as needed. The primary and secondary closing speed adjustments should also be set and maintained in accordance with the manufacturer's recommendations. The device should allow the door to operate freely and smoothly throughout its entire swing range and positively latch (if so equipped) or remain in the closed position.

**Areas to be Inspected . . . (Continued)****Surface Bolts/Flush Bolts**

Check all surface bolts/flush bolts for loose attaching screws, rod bolt adjustment and strike plate (on both door and frame if so equipped) attachment. Service the devices or remove defective parts and replace if necessary. The rod bolts should retract, extend and engage the strike or keeper hole freely and smoothly for both manual and/or automatic flush bolts.

**Glass Lites**

The glazing material should be checked for cracks and/or missing pieces of glazing. The glazing mounting frame should be checked to assure attaching screws (if used) are tight and the unit is securely attached to the door. Service the glass lite or remove defective parts and replace as needed. Also be sure to use approved safety glass in appropriate applications/locations, or fire rated glass and glazing in fire doors, windows or lites.

**Door and Frame Finish**

A general visual inspection of the door and frame finish should be periodically conducted. Any excessive finish defects should be repaired and repainted. Adequate protection is needed to prevent the product from rusting prematurely and shortening its service life.

**Unobstructed Operation**

Fire rated and/or smoke and draft control assemblies are specified and installed to meet "safety to life code requirements". It is imperative that these assemblies receive regularly scheduled maintenance checks for all of the above items. Additionally, for the assembly to serve its purpose of stopping fire and/or smoke propagation it must function freely with the ability to positive latch in the closed position. Therefore, propping or blocking these doors in an open position is in violation of intended use and purpose as established in building codes. These doors must not be obstructed in any fashion which would prevent them from functioning as intended.

**Related Documents:**

- SDI 124 Maintenance of Hollow Metal Doors and Frames
- SDI 122 Installation and Trouble Shooters Guide for Standard Steel Doors and Frames
- NFPA-80 Fire Doors and Windows - Chapter #15



## **PAINTING INSTRUCTIONS**

### **INSPECT FOR DAMAGE**

REPAIR AS NECESSARY (scratches, dents, etc.)

Scratches: Sand lightly to obtain smooth surface.

Dents: Sand to bare metal and fill with automotive body filler. After the filler has cured, sand to a smooth flat surface.

Prime repair spots with a low gloss oil base primer.

FINISH PAINT USE LOW GLOSS OIL BASE FINISH PAINT DO NOT USE WATER BASE FINISH PAINT, UNLESS THE DOOR IS REPRIMED WITH A BARE METAL TYPE PRIMER.

It is the responsibility of the user to maintain the integrity of the finish after receipt and installation of the door.



# *Warranty*

Revised Oct 1, 1998

**First**, we offer a 100% parts warranty for one year from date of initial shipment on any damaged or defective product, provided that the “damage” is not a result of negligence from a second party. (Second party meaning freight damage, contractor damage, etc.) Dominion will replace products that are damaged due to negligence at your standard price. Incidentally, freight damage claims must come from the receiver and go through the company that transported the product, and there is usually a short time within which claims can be filed. Dominion cannot issue freight claims.

**Second**, all defective or damaged products must be returned to Dominion to receive credit unless otherwise instructed by a Dominion representative. If a product is not returned, no credit will be issued, again, unless instructed otherwise.

**Third**, when returning product, make absolutely sure that some documentation accompanies the product to indicate OUR customer name, OUR order number, or OUR invoice number, etc. A copy of the original packing slip would be ideal. Failure to do so will make it exceedingly difficult to issue credit to the appropriate party.

**Finally**, in order to expedite a warranty item, we will always issue an invoice for the price of the replacement component. Upon receipt of the returned defective product, we will issue a second invoice showing a negative balance for the same amount (a credit) which effectively cancels the first. If we never receive the returned item, the first invoice is payable according to your normal terms. Unless explicitly instructed by a Dominion representative, credits and partial payments should NEVER be taken on any Dominion invoice. Doing so will constitute an outstanding invoice and will cause difficulty in cleaning up outstanding balances.

Our desire is to make the warranty policy a straightforward and easy one to use. To that end, periodically it becomes necessary to modify procedures and policies to make a given process more streamlined and cost effective for everyone involved. As we have reviewed the WARRANTY policy, we hope this clarification will assist you in your warranty and credit issues.