

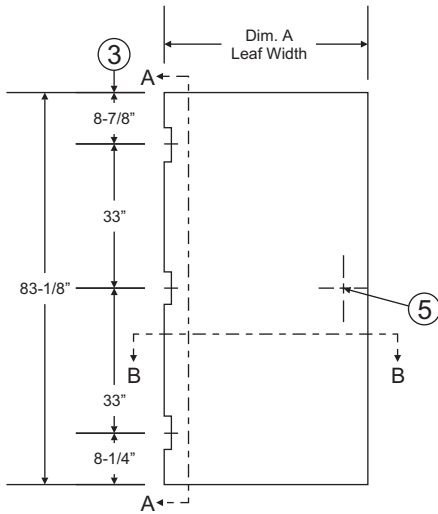

Honeycomb Door Leaf

8-1-99



ELEVATION "F" DESIGN

- ① Vertical edge seams mechanically interlocked
- ② Square hinge and lock edges
- ③ 4-1/2" x .134" full mortise hinge prep
- ⑤ Gov. 160/161 cyl lock prep ...prefix VCR

MATERIAL: Face sheets -- 20 gage, textured - galvanized steel. 16 gage steel flush-mounted top and bottom channels. 7 gage steel hinge reinforcements. Core -- resin impregnated, sanded edge, kraft fiber honeycomb with a nominal one inch cell size. Core is laminated to top and bottom face sheets by means of moisture resistant, contact type adhesive.

FINISH: BRONZE OR WHITE

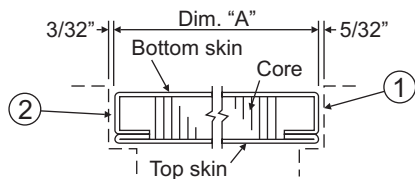

SECTION BB

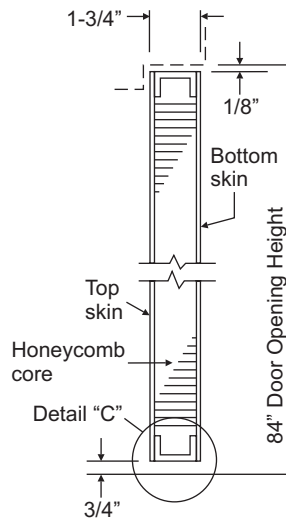

SECTION AA

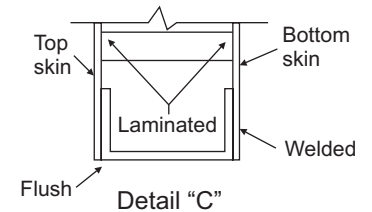

Lite Kits

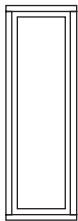

Narrow Lite
6-5/8" x 36-5/8"

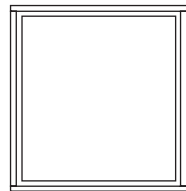

Half-Glass
23-3/4" x 29-7/16"
35-3/4" x 29-7/16"

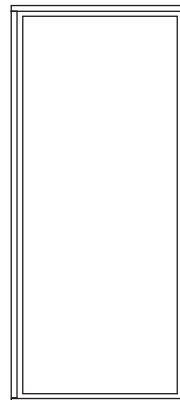

Full-Glass
23-3/4" x 63-1/2"



Honeycomb Door Leaf

8-1-99

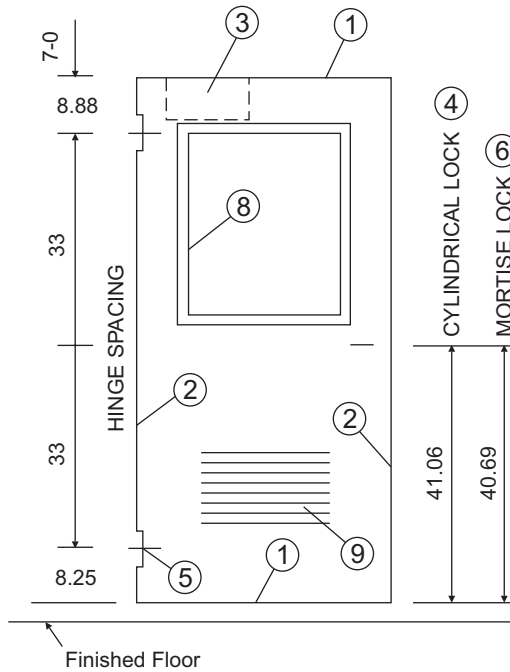

DOOR ELEVATION

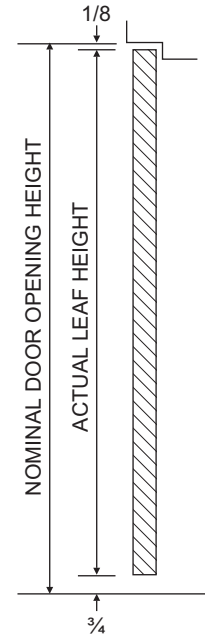

VERTICAL SECTION

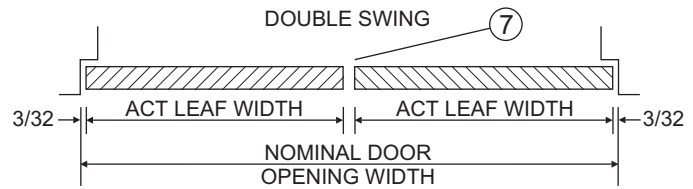
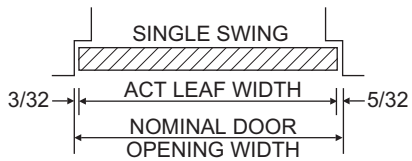

HORIZONTAL SECTIONS

(Conversion: 1" = 25.4 mm, e.g., 1-3/4" = 44.45 mm)

OVERLAPPING ASTRAGAL
4451
FOR 1-3/4" THICK
DOORS WITH OPTIONAL
POLY-PILE INSERT

7

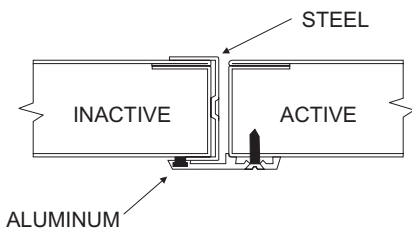

SPLIT ASTRAGAL
4461
WITH WOOL-PILE
INSERT

7

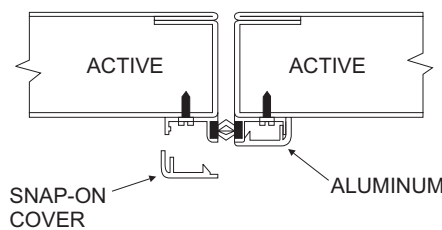

OVERLAPPING ASTRAGAL
4461
FOR 1-3/4" THICK
DOORS

7

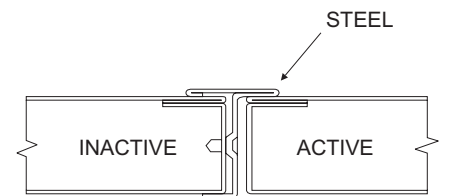

LISTED



Honeycomb Door Leaf

8-1-99

16 GAGE STEEL
END CHANNELS
WELDED
TO DOOR

FLUSH
TOP AND
BOTTOM
CHANNELS

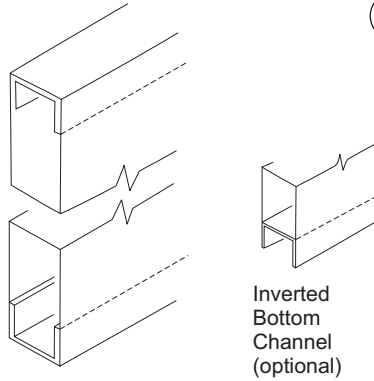

Inverted
Bottom
Channel
(optional)

1

VERTICAL EDGES

MECHANICALLY
INTERLOCKED
HEMMED EDGES

ALSO AVAILABLE
SEAMLESS (WELDED
OR BODY FILLER)

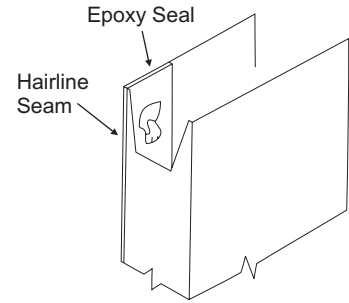

2

CLOSER
REINFORCEMENT
(OPTIONAL)

12 GAGE
STEEL
CHANNEL
16" LONG

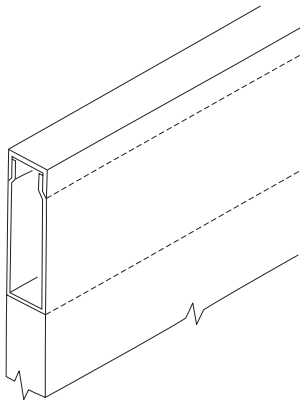

3

LOCK PREPARATION
GOV. 160/161
CYLINDRICAL TYPE

(C)

(ANSI A115.2)
2-3/4"
BACKSET

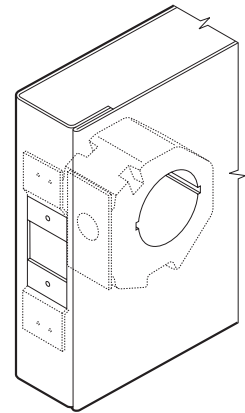

4

HINGE
PREPARATION

4-1/2" X .134"
HIGH, STANDARD
OR HEAVY WT.
FULL MORTISE
HINGE
PREPS

ANSI A156.7
TEMPLATE

NON-HANDED

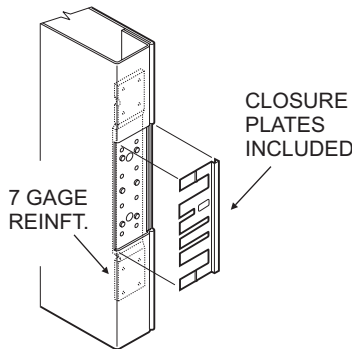

5

LOCK
PREPARATION
GOV. 86-4
MORTISE TYPE

(M) (ANSI a115.1)
2-3/4" BACKSET
(B) SIMILAR TO DETAIL
LESS FACE CUTOUT
(P) SIMILAR TO DETAIL
LESS ALL CUTOUT
AND REINFORCEMENT

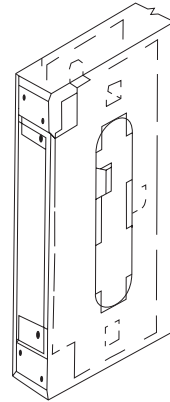

6

GLAZING TRIM
4831 (APPLIED)
FOR STANDARD
FLUSH DOORS

ALUMINUM

SNAP-IN
BEAD

3/8" WIDE
GLAZING
POCKET

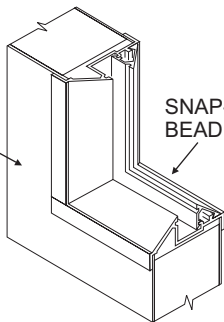

8

GLAZING TRIM
4841 (APPLIED)
FOR ALL
FIRE DOORS

3/8" WIDE
GLAZING
POCKET

LISTED

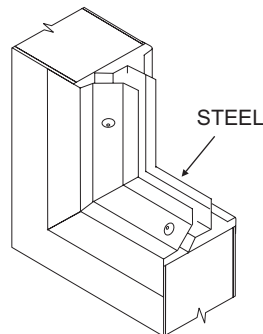

8

PIERCED LOUVER
FOR HONEYCOMB
CORE DOORS

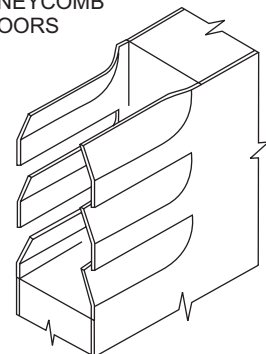

"L" DESIGN

9



Honeycomb Door Leaf

8-1-99

STANDARD SIZES
NOMINAL DOOR OPENING

WIDTH		HEIGHT
SINGLE	DOUBLE	
2'-0"	4'-0"	6'-8" 7'-0" 7'-2" 7'-10" 8'-0" 9'-0"
2'-4"	4'-8"	
2'-6"	5'-0"	
2'-8"	5'-4"	
2'-10"	5'-8"	
3'-0"	6'-0"	
3'-4"	6'-8"	
3'-6"	7'-0"	
3'-8"	7'-4"	
3'-10"	7'-8"	
4'-0"	8'-0"	

PRODUCT SPECIFICATIONS:

1-3/4" thick steel doors shall be as manufactured by Ceco Door Products, Milan, TN USA. Doors shall conform to the Steel Door Institute guide specification ANSI/SDI 100-91; see chart below for performance classifications.

OMEGA doors are made full-flush or (optional) seamless style. Faces sheets are commercial quality cold rolled steel conforming to ASTM A366 or A620 & A568...or (optional) hot-dipped galvanized steel (conforming to ASTM A526 or A642 & A525) - see chart below.

Omega full-flush doors have mechanically interlocked, hemmed, hairline seams on vertical edges and have no visible seams on faces. Doors specified "seamless" have no visible seams on faces or vertical edges. A one piece, chemically-treated, 99 lb., One inch cell, kraft-fibre honeycomb slab is securely bonded to both face sheets under pressure with contact adhesive. The top and bottom door edges are closed flush by 16 gage steel channels welded in place. The bottom edge channel can also be installed inverted (optional).

FIRE DOORS

LABELING AGENCIES:

- UNDERWRITERS LABORATORY
- WARNOCK HERSEY
- FACTORY MUTUAL

- TEST: ASTM E-152, UL10B, UBC 43-2
- RATING: 20 MIN, ¾ HR, 1-1/2 HR, OR 3 HR
 - MAX. SIZE: 40 x 90 SINGLE
80 x 90 PAIR
 - DESIGNS: F, G, N, & V

Not all ratings are available in all sizes, designs and materials.

Hardware Provisions: Hinge preparations are non-handed. Hinge edges are mortised for 4-1/2" standard and heavy weight hinges. 7 gage steel reinforcements are welded inside the door edge and are drilled and tapped for fasteners in accordance with ANSI A156.7. Hinge closing plates are included. The lock edge is square and is prepared for Gov. Series 86, or 160-161 locks in accordance with ANSI A115 (specify which). Optional closer reinforcement is a 12 gage steel channel.

Paint: 1-3/4" steel doors shall be provided with one coat of oven-cured neutral color primer paint. Primer coat shall conform with ANSI A224.1-1990 with the thickness of primer coat not being less than 0.7 mils. The primer coat is a preparatory base for necessary finish painting. "Colorstyle" finish coat is also available from a selection of standard colors (optional). Colorstyle finish is electrostatically applied, oven-cured urethane enamel. For accurate color selectors ask for a Ceco Colorstyle chart.

MATERIAL

DOOR FACE SHEETS	GRADE	C.R.	GALV		RECOMMENDED DOOR FRAME MATERIAL
			A60	G90	
20 Gage Textured Steel (4080 max.)	Standard Duty	STD	OPT	-	16 Gage Steel
20 Gage Steel (4080 max.)	Standard Duty	STD	OPT	-	16 Gage Steel
18 Gage Steel	Heavy Duty	STD	OPT	OPT	16 Gage Steel
16 Gage Steel	Extra Heavy Duty	STD	OPT	OPT	16 or 14 Gage Steel

PERFORMANCE

Core Thermal Characters:	U Factor: 0.067 R Factor: 14.97
Sound Transmission Class:	STC 26 (F Design, 18 Gage Face Sheets, ASTM E90-81 & E413-73 [Fully Operable])
Physical Endurance Level:	Meets ANSI A 151.1 Performance Test, 20 GAGE: Level B (500,000 Cycles); 18 and 16: Level A (1,000,000 Cycles)



Honeycomb Door Leaf

8-1-99

WALK DOOR SYSTEM
HONEYCOMB CORE

PERFORMANCE TESTS

<u>Description</u>	<u>Test Method</u>	<u>Results</u>
1. Slam Test	ANSI A151.1-81	1,000,000 Cycles. Grade 1 without failure
2. Twist or torque test	ANSI A151.1-81	Max. defl. At 300# = .800" max. Permanent set = .029".
3. Acoustical properties	ASTM E90-61T	STC rating of 32.
4. Insulation properties	ASTM C236 Mod.	"U" factor = 0.041. "R" factor = 2.44.
5. Standard fire rating * Must be installed in fire rated frame.	ASTM E152	Door is rated at 1-1/2" hours. (class "B" label)
6. Paint performance	ASTM B117 ASTM D2247 Weatherometer	200 hrs. salt spray. 500 hrs. humidity. 1000 hrs.

CONFORMANCE TO NATIONALLY ACCEPTED SPECIFICATIONS AND STANDARDS

<u>Requirements</u>	<u>Complies</u>
1. ANSI/SDI 100	YES
2. RR-D-575B	YES
3. PBS 4-0810	YES
4. CS 242-62	YES
5. CEGS-08110	YES
6. NFGS-08110	YES
7. H-08-1, 08110	YES
8. UL 10B/ANSI A2.2	YES
9. ANSI A115	YES
10. ANSI A156.7	YES
11. NFPA 80	YES
12. ASHRAE 90	YES (if weatherstripped)
13. ASTM D-2247	500 hrs.
14. ASTM B-117	200 hrs.
15. ASTM A-525	A-60 Coating Designation
16. ASTM A-366	Uncoated
17. PS-4-66	YES
18. CS-9-65	YES
19. ANSI A224.1-80	YES
20. ASTM C236 Mod.	YES